

FEATURES

- A fuse with an indicator that shows evidence of fusing is also available (microswitch can be installed).
- Durable against repetitive current.
- Compliant with various standards.
- It is also effective as a fuse with high breaking performance for systems operating at 200V.

RATING

Rated voltage and breaking capacity: 660V AC–100kA,
660V DC (L/R = 10ms)–100kA
Minimum breaking current: 660V AC/DC – 5 times the rated amperage
Maximum arc voltage: 1400V

UL standard approved rating

Rated voltage and breaking capacity: Same as the standard rating

CCC standard approved rating

When applying the standard to CCC standard approved items, use the fuse in the following rating.

*The CCC standard is an option. Enter "TC" at the end of product name when ordering (e.g., 660GH-200ULTC)

Rated voltage and breaking capacity : 660V AC–50kA
450V DC (L/R = 15ms)–50kA

CAUTION!

- Read "FOR SAFE USE" and "PROTECT FUSE USER'S GUIDE" at the back of this catalog before use.
- When purchasing a product with an indicator fuse, enter "S" immediately after the ampere rating in the product name (e.g., 660GH-100SUL).
- The minimum working voltage of the indicator fuse is 10V.

Specifications

Type	Rated Amperage (A)	Fusing I ² t (A ² S)	Shutdown I ² t (A ² S) at AC660V-100KA	Power Loss (W)	Dimensions (mm)											Weight (g)	Fig	Standard Approved
					A	B	C	D	E	F	G	H	T	W	M			
660GH-16UL	16	19	220	2.0	76	61±3	46	27max	17.5	9.5	6.5	19	2	12	—	37	1	
660GH-20UL	20	26	310	3.5														
660GH-25UL	25	42	440	4.0														
660GH-32UL	32	74	770	6.0														
660GH-40UL	40	100	1100	7.0														
660GH-50UL	50	167	1600	9.0														
660GH-63UL	63	300	2700	12.0	98	77±4	50	30max	23	14	9	26	3	20	—	100		
660GH-80UL	80	400	3800	17.0														
660GH-100UL	100	670	7400	22.0														
660GH-125UL	125	1200	10600	25.0	108	82±4	51	51max	31	16	10.5	34	3	25	—	180		
660GH-160UL	160	2100	18000	35.0														
660GH-200UL	200	3300	29000	40.0														
660GH-250UL	250	6000	49500	50.0	107	81±3	51	51max	37	13	11	40	3	30	—	260		
660GH-315UL	315	7400	63000	80.0														
660GH-350	350	11000	92000	70.0														
660GH-400	400	14000	112000	85.0	107	81±3	51	51max	37	13	11	43	6	30	80	530	2	—
660GH-450	450	24000	210000	85.0														
660GH-500	500	29000	270000	95.0														
660GH-630	630	42000	390000	105.0	107	81±3	51	51max	37	13	11	43	6	30	80	530	2	—
660GH-710	710	51000	460000	115.0														

Dimensions

Fig 1

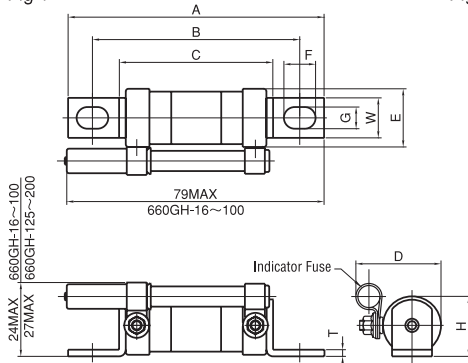
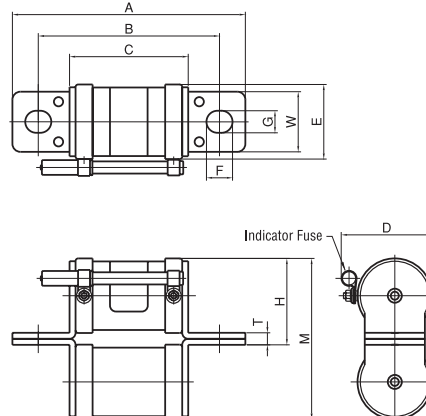
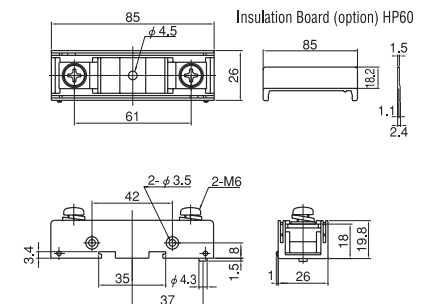

Fig 2



Fuse Holder HT6017 (refer to P.29)



Fusing Characteristics

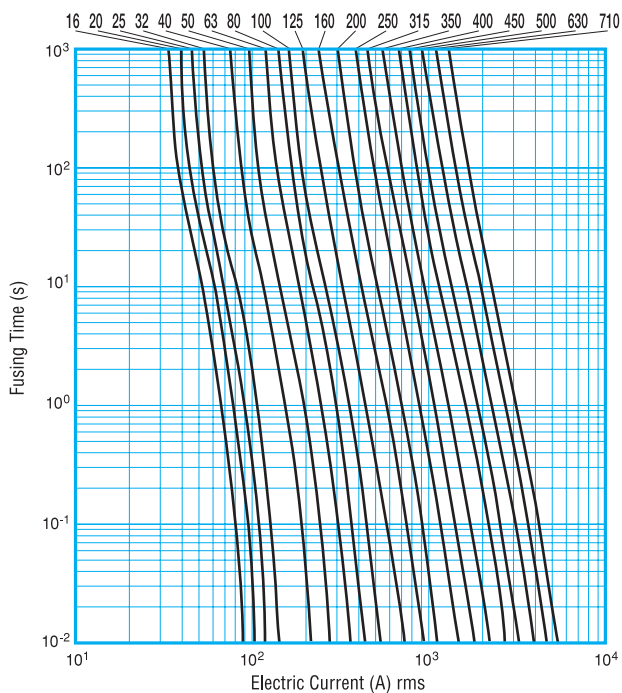

Current-Limiting Characteristics

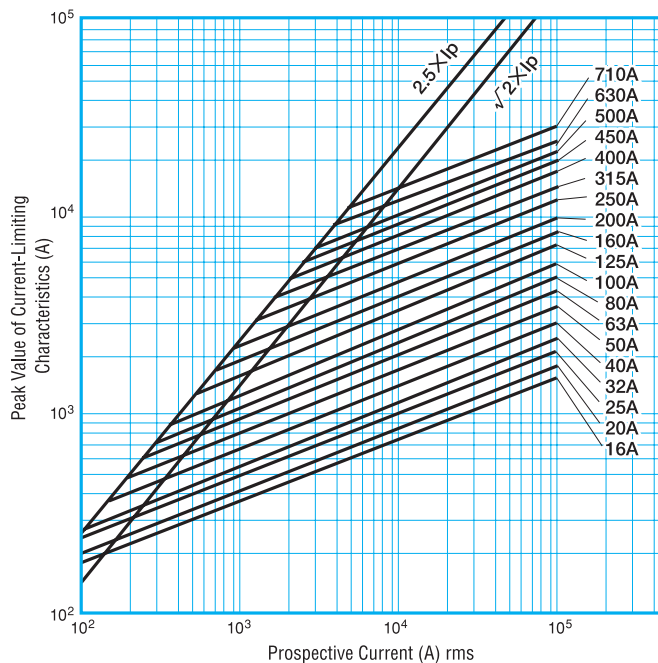

Temperature Rise

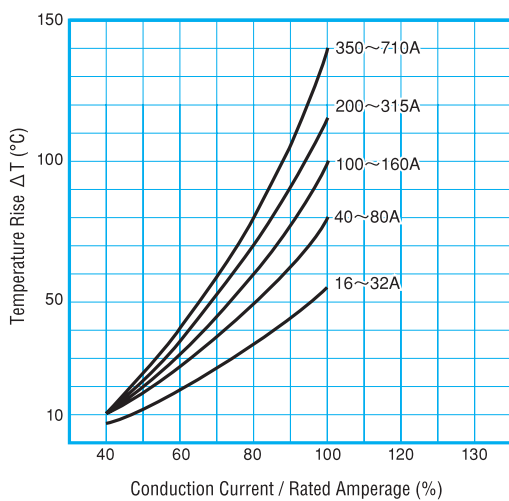

Power Loss

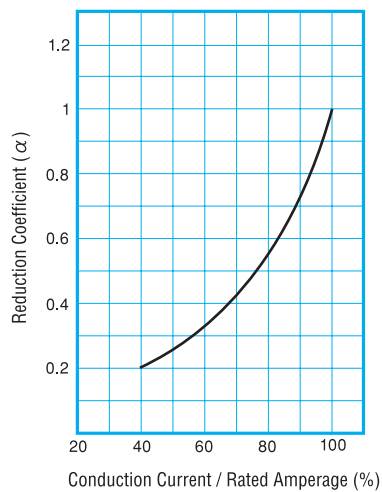

Shutdown I^2t Against Working AC Voltage

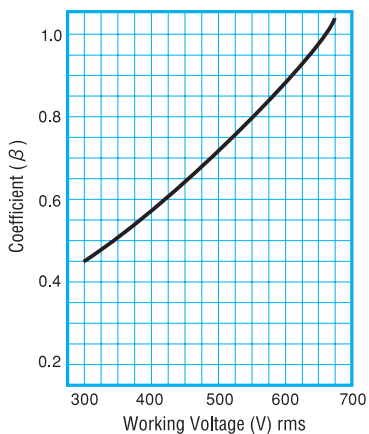

Application to Direct-Current Circuit

